

INSTRUCTION SHEET



**ROOK/FINCH CANOPY (Ø5")
MOUNT, CORD SUSPENSION (C.C)**

689-20098

PAGE 1 OF 1

WARNING - RISK OF FIRE AND ELECTRICAL SHOCK. FIXTURE MUST BE INSTALLED BY A QUALIFIED ELECTRICIAN ONLY. FIXTURE IS INTENDED FOR INSTALLATION IN ACCORDANCE WITH THE NATIONAL ELECTRICAL CODE, LOCAL AND FEDERAL SPECIFICATIONS. DISCONNECT POWER AT ELECTRICAL PANEL BEFORE SERVICING.

RETAIN THESE INSTRUCTIONS FOR MAINTENANCE REFERENCE.

- 1** THREAD CORD GRIP BASE INTO CROSSBAR
- 2** ATTACH CROSSBAR TO JUNCTION BOX (B.O.) WITH HARDWARE (B.O.)
- 3** FEED FIXTURE POWER CORD THROUGH CORD GRIP CAP, THEN CANOPY, THEN CORD GRIP BASE, ADJUSTING SUSPENSION HEIGHT. CUT AND STRIP EXCESS POWER CORD AS NEEDED.
- 4** SPLICE FIXTURE WIRES TO INCOMING WIRES
- 5** THREAD CORD GRIP CAP ONTO CORD GRIP BASE, SECURING CANOPY

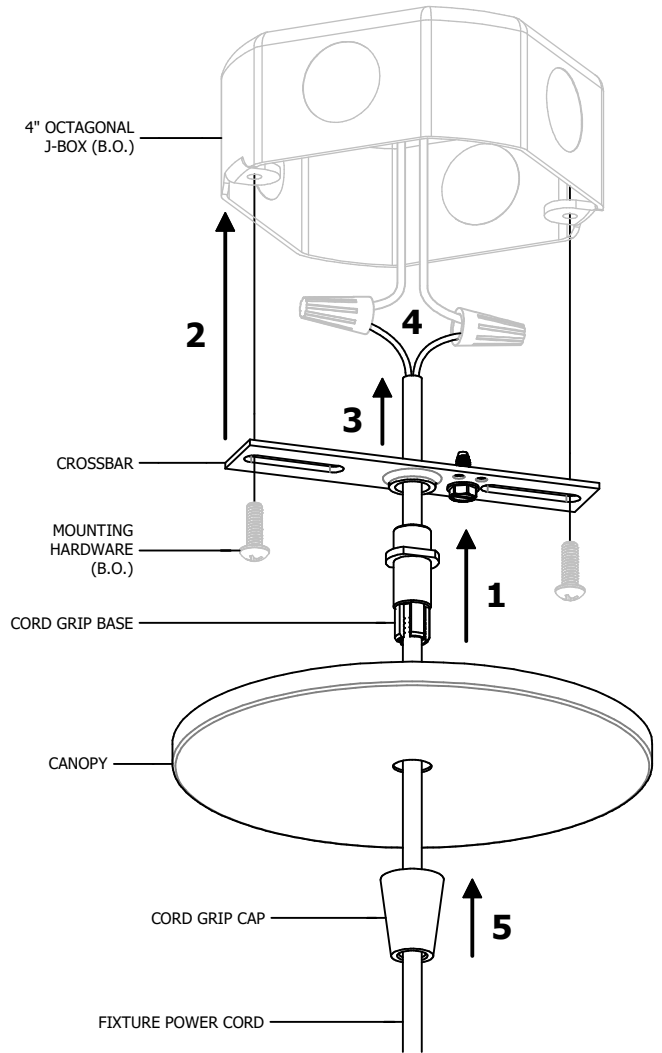

2-WIRE

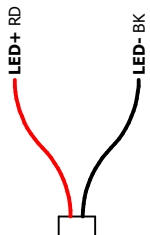

4-WIRE

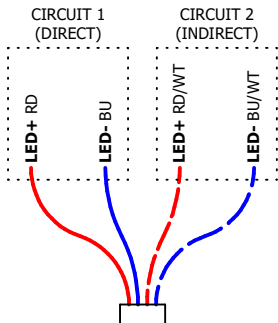

5-WIRE

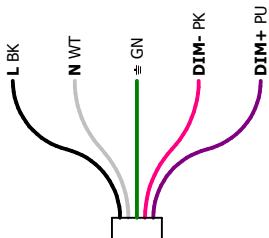

9-WIRE

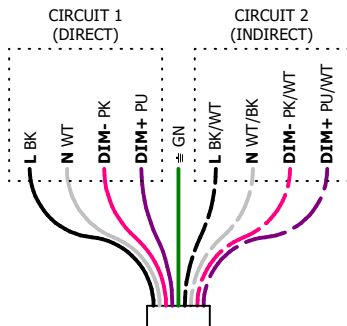

Amerlux, 178 Bauer Drive, Oakland, N.J. 07436, T: 973-882-5010, F: 973-882-2604 www.amerlux.com



INSTRUCTION SHEET

ROOK/FINCH CANOPY (Ø5") MOUNT, TOP END FIELD CUTTABLE RIGID STEM SUSPENSION (C.RS)

689-20124

PAGE 1 OF 1

WARNING - RISK OF FIRE AND ELECTRICAL SHOCK. FIXTURE MUST BE INSTALLED BY A QUALIFIED ELECTRICIAN ONLY. FIXTURE IS INTENDED FOR INSTALLATION IN ACCORDANCE WITH THE NATIONAL ELECTRICAL CODE, LOCAL AND FEDERAL SPECIFICATIONS. DISCONNECT POWER AT ELECTRICAL PANEL BEFORE SERVICING.

RETAIN THESE INSTRUCTIONS FOR MAINTENANCE REFERENCE.

- 1 ATTACH CROSSBAR ASSEMBLY TO JUNCTION BOX (B.O.) WITH MOUNTING HARDWARE (B.O.)
- 2 IF NECESSARY, CUT STEM TO DESIRED LENGTH THEN DRILL A Ø1/8 THRU HOLE 1/4" FROM CUT END
- 3 FEED FIXTURE WIRES THROUGH STEM THEN FULLY THREAD FIXTURE AND STEM TOGETHER
- 4 SLIDE CANOPY OVER STEM THEN FEED FIXTURE WIRES THROUGH CROSSBAR HUB
- 5 ALIGN STEM HOLES TO CROSSBAR HUB SET SCREWS, THEN FULLY TIGHTEN SET SCREWS, SECURING STEM
- 6 SPLICE FIXTURE WIRES TO INCOMING WIRES ACCORDING TO LOCAL AND NATIONAL CODE
- 7 RAISE CANOPY TO MAGNETIC CROSSBAR

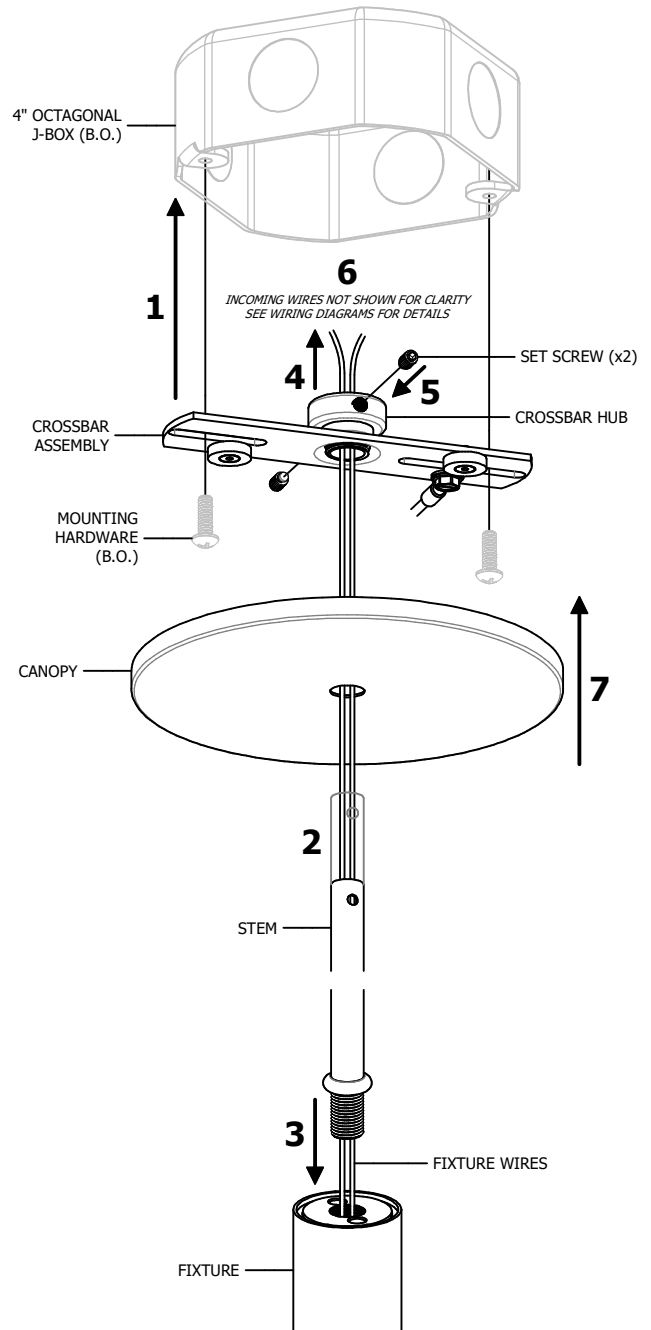

2-WIRE

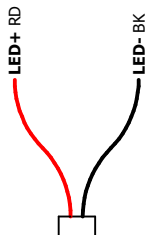

4-WIRE

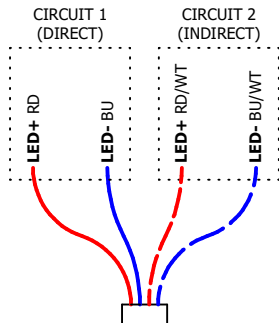

5-WIRE

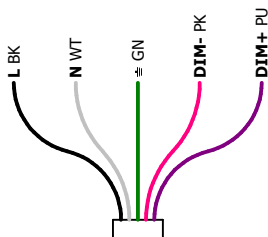

9-WIRE

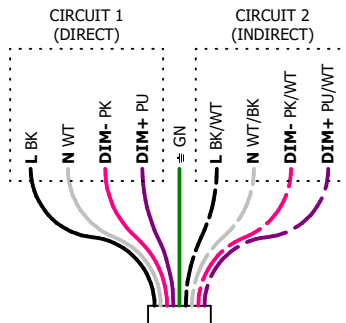

Amerlux, 178 Bauer Drive, Oakland, N.J. 07436, T: 973-882-5010, F: 973-882-2604 www.amerlux.com

INSTRUCTION SHEET



ROOK/FINCH CANOPY (Ø5") MOUNT, TOP END FIELD CUTTABLE SWIVEL STEM SUSPENSION (C.SS)

689-20125

PAGE 1 OF 1

WARNING - RISK OF FIRE AND ELECTRICAL SHOCK. FIXTURE MUST BE INSTALLED BY A QUALIFIED ELECTRICIAN ONLY. FIXTURE IS INTENDED FOR INSTALLATION IN ACCORDANCE WITH THE NATIONAL ELECTRICAL CODE, LOCAL AND FEDERAL SPECIFICATIONS. DISCONNECT POWER AT ELECTRICAL PANEL BEFORE SERVICING.

RETAIN THESE INSTRUCTIONS FOR MAINTENANCE REFERENCE.

- 1** ATTACH CROSSBAR ASSEMBLY TO JUNCTION BOX (B.O.) WITH MOUNTING HARDWARE (B.O.)
- 2** IF NECESSARY, CUT STEM TO DESIRED LENGTH THEN DRILL A Ø1/8 THRU HOLE 1/4" FROM CUT END
- 3** FEED FIXTURE WIRES THROUGH STEM THEN FULLY THREAD FIXTURE AND STEM TOGETHER
- 4** SLIDE CANOPY AND PLATE OVER STEM, THEN FEED FIXTURE WIRES THROUGH HALF BALL
- 5** ALIGN STEM HOLES TO HALF BALL SET SCREWS, THEN FULLY TIGHTEN SET SCREWS, SECURING STEM
- 6** INSERT BUSHING INTO SWIVEL CLIP AND SLIDE CLIP ONTO PLATE, FEEDING FIXTURE WIRES THROUGH BUSHING
- 7** SPLICE FIXTURE WIRES TO INCOMING WIRES ACCORDING TO LOCAL AND NATIONAL CODE
- 8** LIFT PLATE UP THROUGH CROSSBAR HOLE, THEN SHIFT INTO PLACE AND SECURE PLATE TO CROSSBAR WITH SEMS SCREW
- 9** RAISE CANOPY TO MAGNETIC CROSSBAR

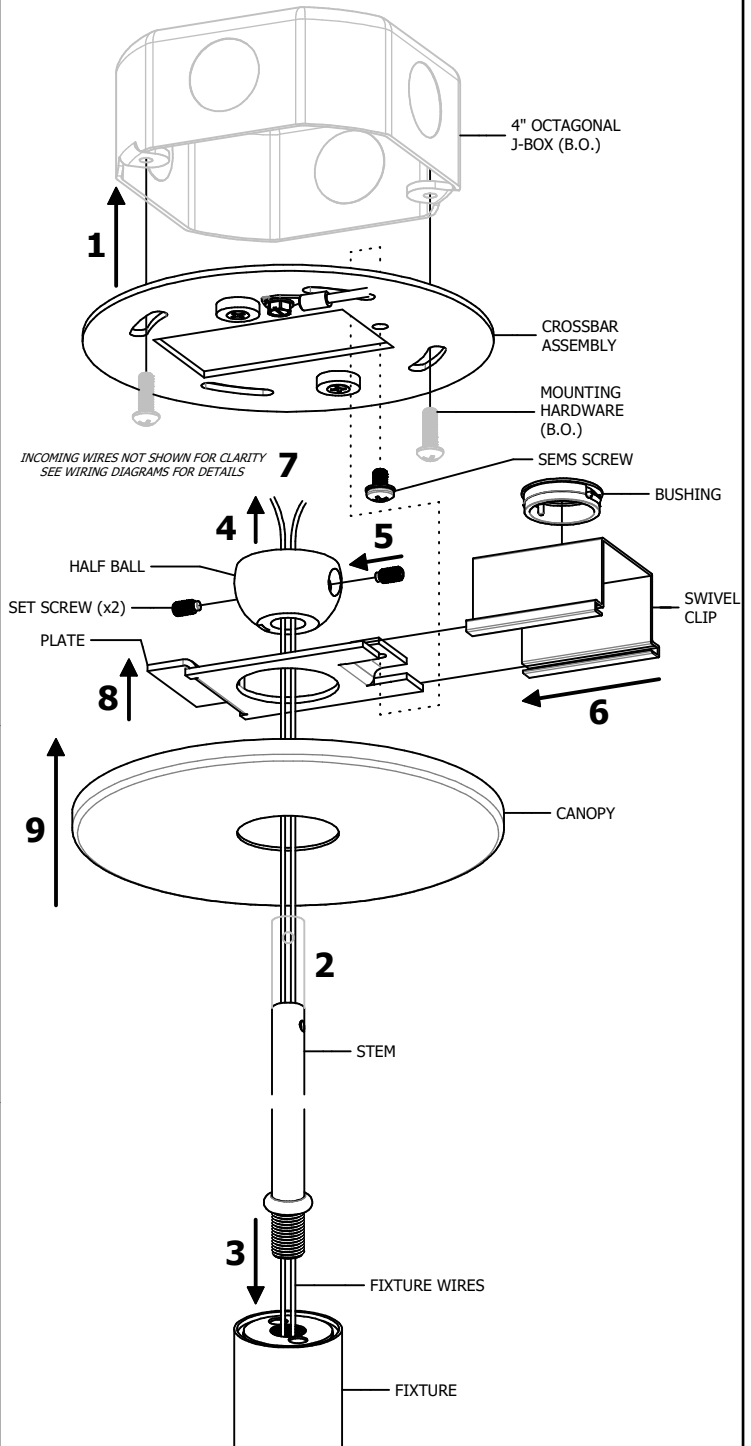

2-WIRE

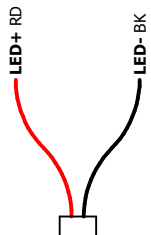

4-WIRE

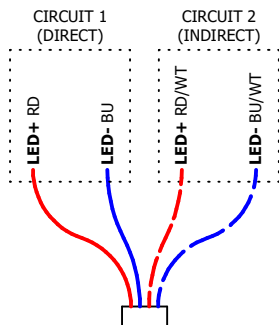

5-WIRE

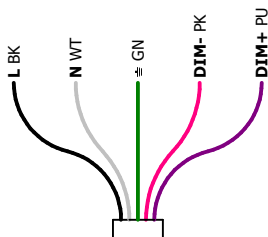

9-WIRE

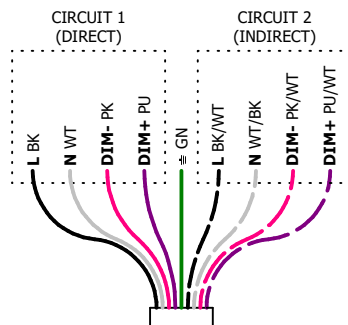

Amerlux, 178 Bauer Drive, Oakland, N.J. 07436, T: 973-882-5010, F: 973-882-2604 www.amerlux.com