

**INSTRUCTION SHEET**



**ROOK/FINCH POWER CONDUIT CANOPY MOUNT, CORD SUSPENSION (PCDC.C)**

**689-20234**

PAGE 1 OF 1

**WARNING - RISK OF FIRE AND ELECTRICAL SHOCK. FIXTURE MUST BE INSTALLED BY A QUALIFIED ELECTRICIAN ONLY. FIXTURE IS INTENDED FOR INSTALLATION IN ACCORDANCE WITH THE NATIONAL ELECTRICAL CODE, LOCAL AND FEDERAL SPECIFICATIONS. DISCONNECT POWER AT ELECTRICAL PANEL BEFORE SERVICING.**

**RETAIN THESE INSTRUCTIONS FOR MAINTENANCE REFERENCE.**

- 1** SPLICE INCOMING WIRES TO DRIVER INPUT WIRES ACCORDING TO LOCAL AND NATIONAL CODE
- 2** ATTACH DRIVER PLATE TO JUNCTION BOX (B.O.) WITH MOUNTING HARDWARE (B.O.). DO NOT FULLY TIGHTEN HARDWARE.
- 3** FEED FIXTURE POWER CORD THROUGH CORD GRIP CAP, THEN CANOPY, THEN CORD GRIP BASE, ADJUSTING SUSPENSION HEIGHT. CUT AND STRIP EXCESS POWER CORD AS NEEDED.
- 4** ATTACH CROSSBAR ASSEMBLY TO DRIVER PLATE AND MOUNTING HARDWARE, THEN FULLY TIGHTEN MOUNTING HARDWARE
- 5** SPLICE FIXTURE POWER CORD WIRES TO DRIVER OUTPUT WIRES WITH SUPPLIED LEVER CONNECTORS
- 6** FULLY THREAD CORD GRIP CAP ONTO CORD GRIP BASE, REMOVING CANOPY KNOCKOUTS AS NEEDED

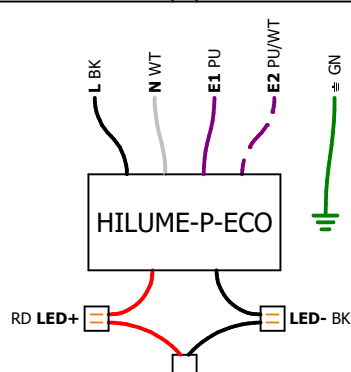
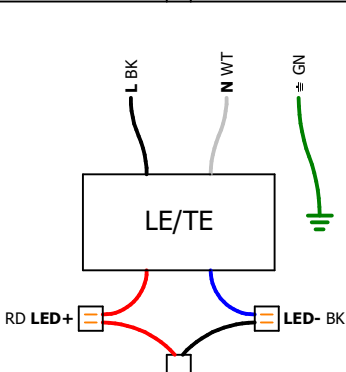
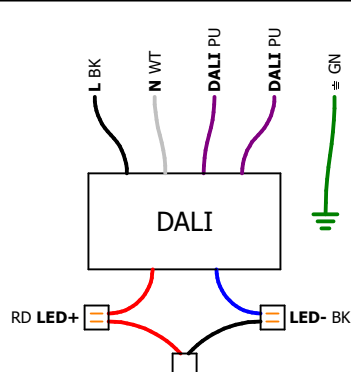
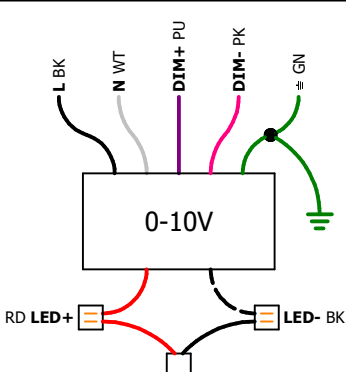
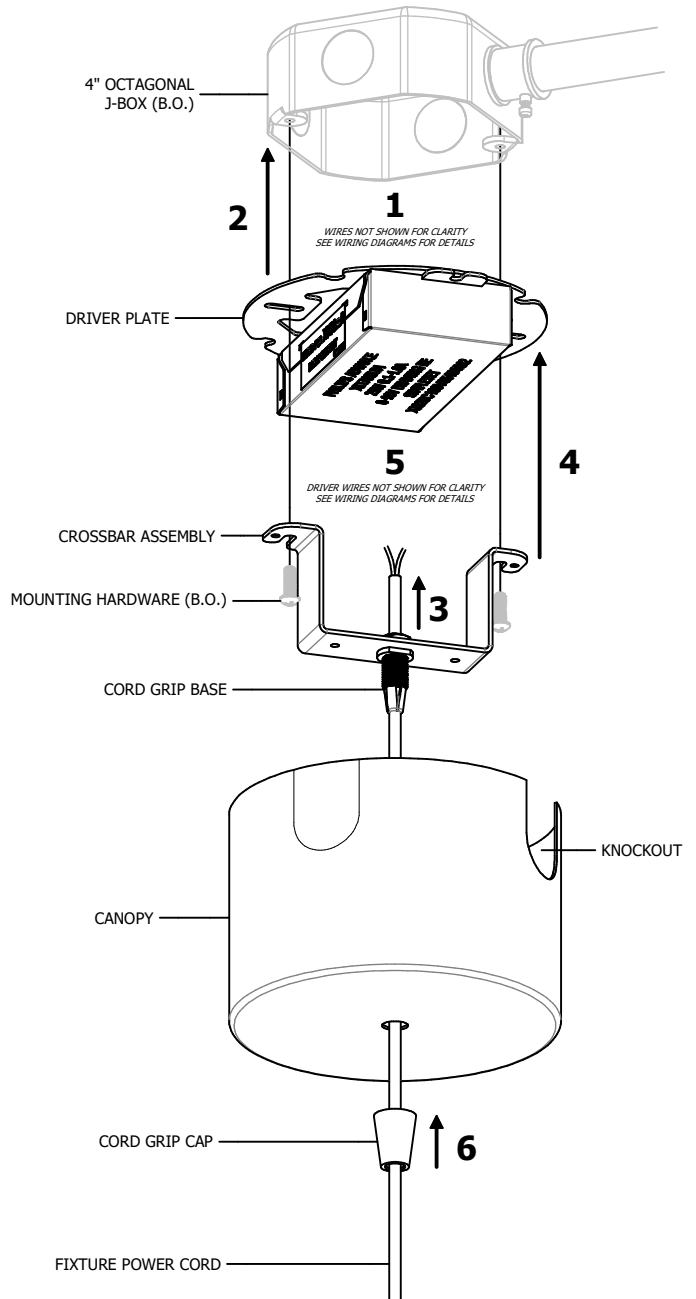

**Amerlux, 178 Bauer Drive, Oakland, N.J. 07436, T: 973-882-5010, F: 973-882-2604 [www.amerlux.com](http://www.amerlux.com)**

REVISION

DATE

APPROVED

# INSTRUCTION SHEET



## ROOK/FINCH POWER CONDUIT CANOPY MOUNT, TOP END FIELD CUTTABLE RIGID STEM SUSPENSION (PCDC.RS)

689-20135

PAGE 1 OF 1

**WARNING - RISK OF FIRE AND ELECTRICAL SHOCK. FIXTURE MUST BE INSTALLED BY A QUALIFIED ELECTRICIAN ONLY. FIXTURE IS INTENDED FOR INSTALLATION IN ACCORDANCE WITH THE NATIONAL ELECTRICAL CODE, LOCAL AND FEDERAL SPECIFICATIONS. DISCONNECT POWER AT ELECTRICAL PANEL BEFORE SERVICING.**

**RETAIN THESE INSTRUCTIONS FOR MAINTENANCE REFERENCE.**

- 1 SPLICE INCOMING WIRES TO DRIVER INPUT WIRES ACCORDING TO LOCAL AND NATIONAL CODE
- 2 ATTACH DRIVER PLATE TO JUNCTION BOX (B.O.) WITH MOUNTING HARDWARE (B.O.). DO NOT FULLY TIGHTEN HARDWARE.
- 3 IF NECESSARY, CUT TOP OF STEM TO DESIRED LENGTH, THEN DRILL A  $\varnothing 1/8$  HOLE THROUGH STEM WALLS, LOCATED 1/4" FROM STEM END
- 4 FEED FIXTURE WIRES THROUGH STEM, THEN FULLY THREAD FIXTURE AND STEM TOGETHER
- 5 SLIDE CANOPY OVER STEM, THEN FEED FIXTURE WIRES THROUGH CROSSBAR HUB
- 6 ALIGN STEM HOLES TO CROSSBAR HUB SET SCREWS, THEN FULLY TIGHTEN SET SCREWS, SECURING STEM
- 7 ATTACH CROSSBAR ASSEMBLY TO DRIVER PLATE AND MOUNTING HARDWARE, THEN FULLY TIGHTEN MOUNTING HARDWARE
- 8 SPLICE FIXTURE WIRES TO DRIVER OUTPUT WIRES WITH SUPPLIED LEVER CONNECTORS
- 9 RAISE CANOPY TO MAGNETIC CROSSBAR, REMOVING K.O.S AS NEEDED

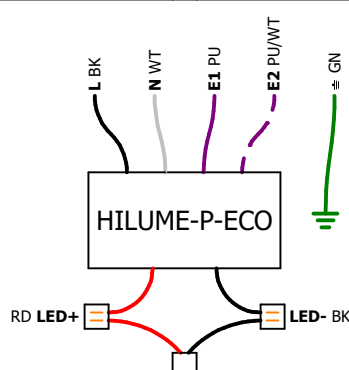
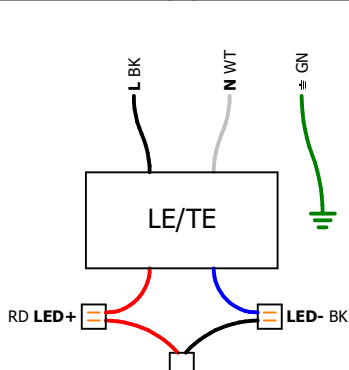
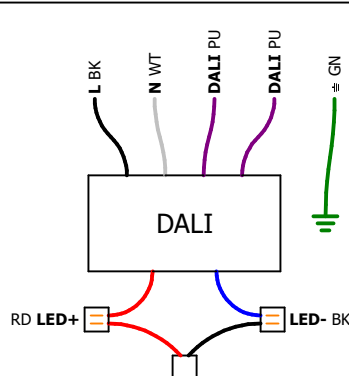
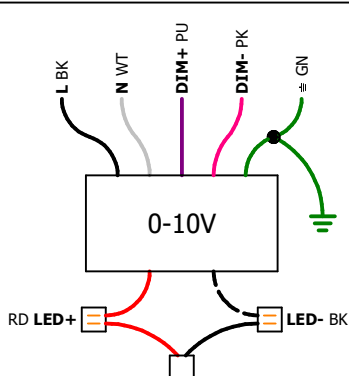
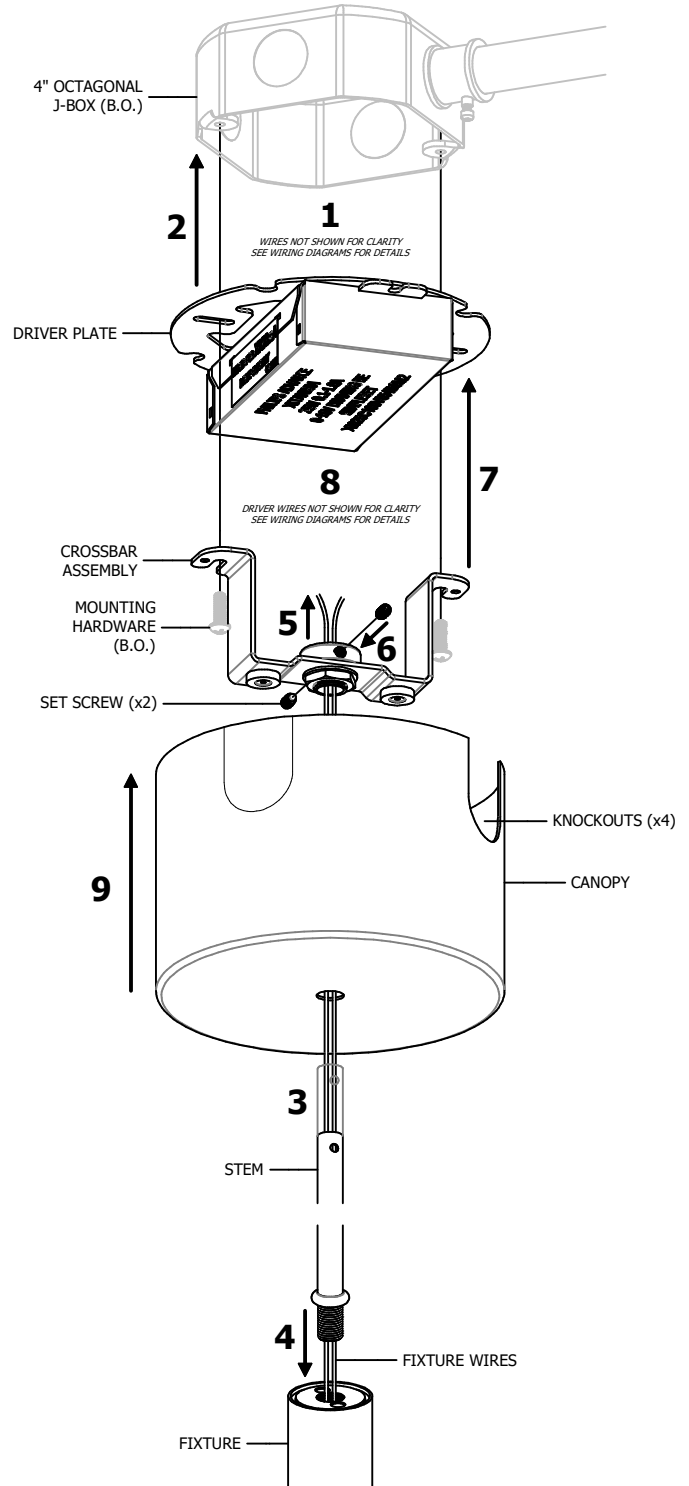

Amerlux, 178 Bauer Drive, Oakland, N.J. 07436, T: 973-882-5010, F: 973-882-2604 [www.amerlux.com](http://www.amerlux.com)