

WARNING - RISK OF FIRE AND ELECTRICAL SHOCK. FIXTURE MUST BE INSTALLED BY A QUALIFIED ELECTRICIAN ONLY. FIXTURE IS INTENDED FOR INSTALLATION IN ACCORDANCE WITH THE NATIONAL ELECTRICAL CODE, LOCAL AND FEDERAL SPECIFICATIONS. DISCONNECT POWER AT ELECTRICAL PANEL BEFORE SERVICING. RETAIN THESE INSTRUCTIONS FOR MAINTENANCE REFERENCE.

Pre-installation Note:

Supplied by Others: - 4" Octagonal J-Box(es)

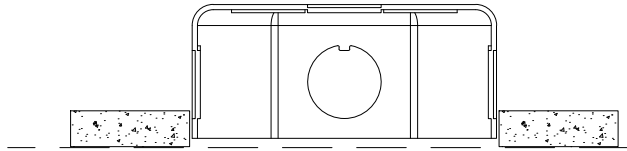

Install junction boxes - The junction box should be regressed as shown to make sure that the canopy cover sits flush with the ceiling when install is finished.

Refer to submittal/shop drawings for proper location of mounting points/ locations for junction boxes.

1: Install Canopy Kits (5" Canopy)

1-1: Feed Location

A: Remove slip ring from coupler (Do Not Lose) Install 1/4-20 screw into crossbar.

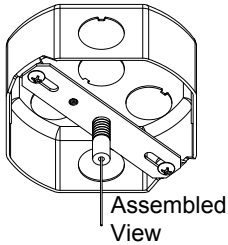
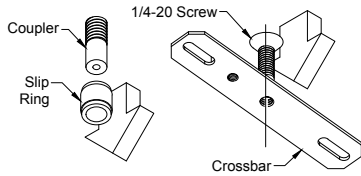

B: Install crossbar assembly into junction box. Thread cable through coupler and fasten to 1/4-20 screw.

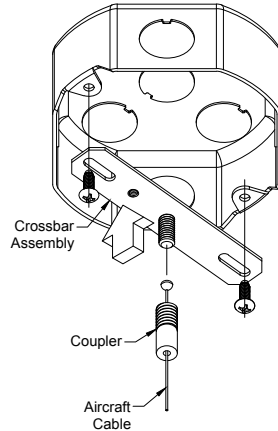

1-2: Non-Feed Location(s)

B: Install crossbar assembly into junction box. Thread cable through coupler. Fit canopy on 1/4-20 screw and secure with coupler to 1/4-20 screw.

A: Install 1/4-20 screw into crossbar.

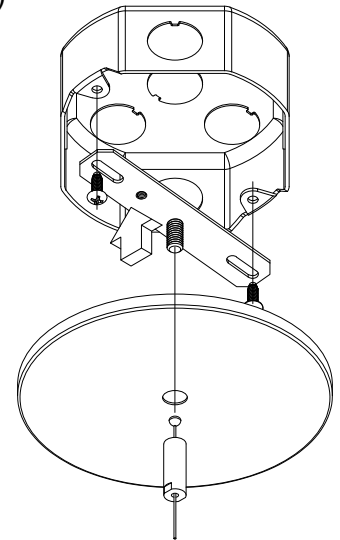
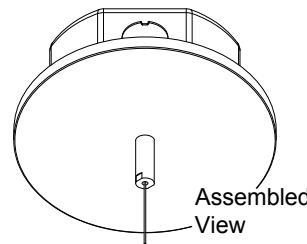
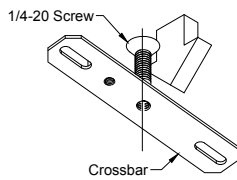

2: Hang Fixture (IND/BoR)

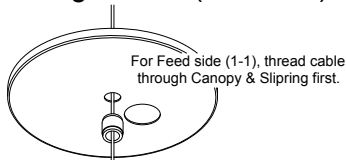

Hanging to suspension cable - Push down plunger and insert cable. Adjust and level fixture in the same manner.

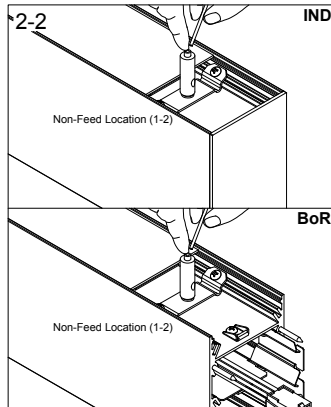
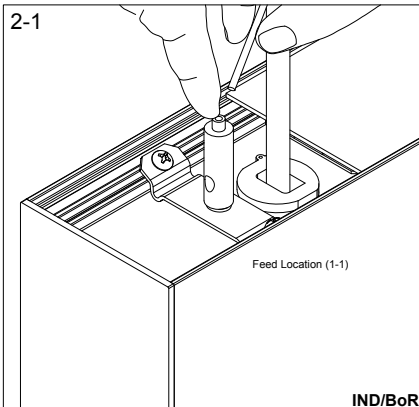
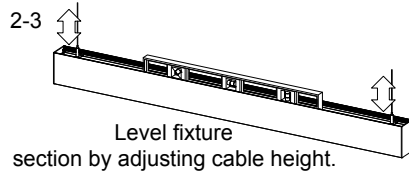
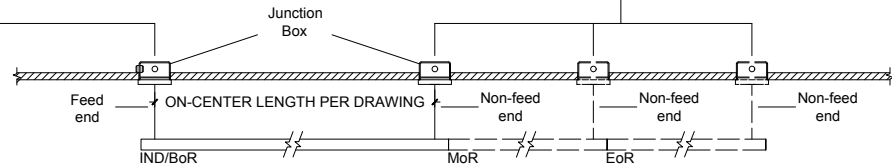

3: Connect Power

3-1

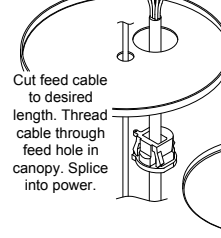

3-2:

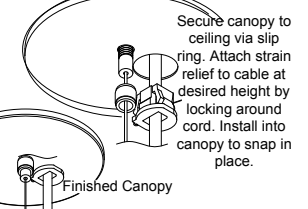

4: Hang Continuous Run (MoR/EoR)*

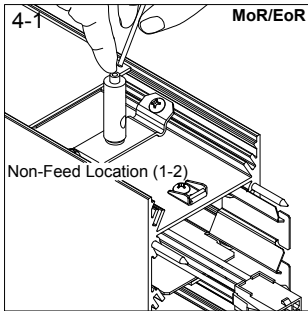

Hang to suspension cable - See Step 2

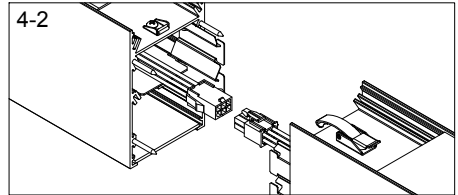
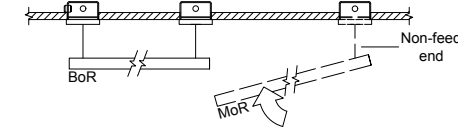

Connect power to fixture via quick-connect harness.

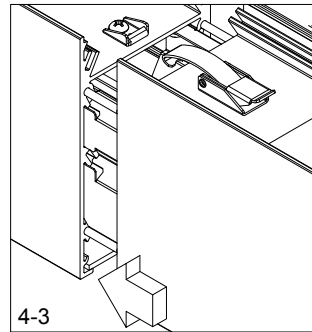

Slide fixtures together using pins and black light shield for alignment

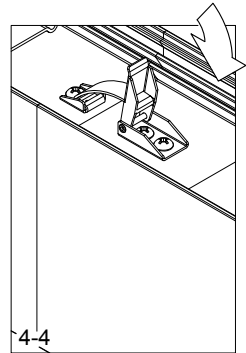

Secure seam using fixture latch

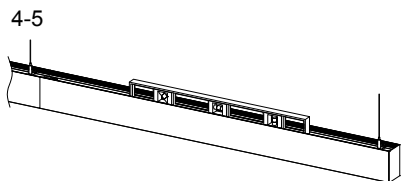

Level fixture section by adjusting cable height.

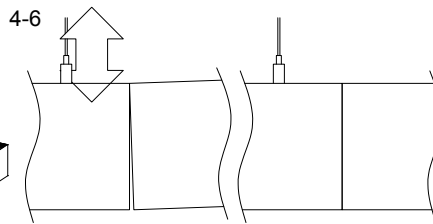

Fine tune cable height to ensure tight seam

5: Hanging curves in patterns (D22, D36, D43)

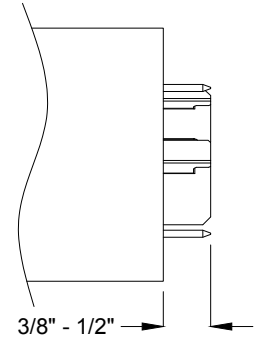
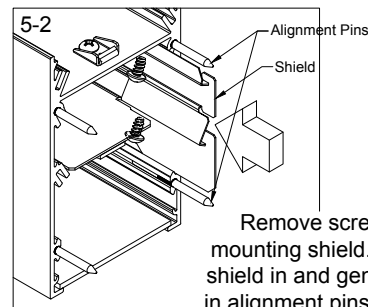
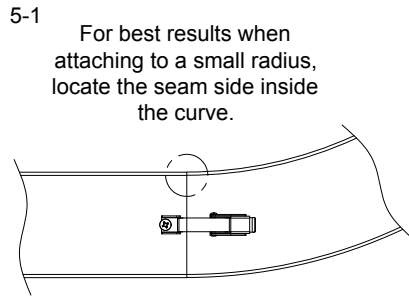

D72 & D100 do not apply. Install like any other MoR

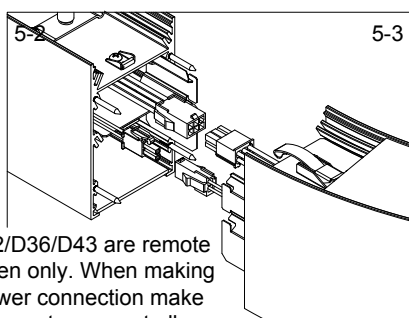

D22/D36/D43 are remote driven only. When making power connection make sure to connect all harnesses.*

*:Verify the correct straight fixture is being connected. Connecting the wrong fixture may result in differences in light intensity.

Repeat step 4 & 5 until run is complete.

6: Install Light Leak Shield (Optional)

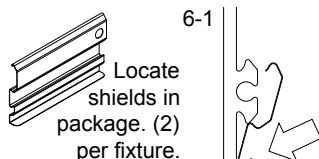

Remove Lens (See pg. 3) Reinstall when complete

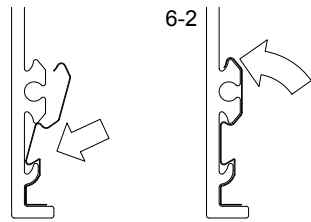

Snap in bottom of shield into hook.

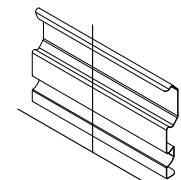

Snap top around extrusion.

For best results make sure the center of the shields aligned with fixture seam

Do this for both sides. Repeat step 6 for all seams in the run.

Maintenance

WARNING: Electrostatic and polarity sensitive device. Use caution while handling and wiring.

1.) LED Fixture:

Consult Amerlux for LED maintenance.

2.) LED Replacement:

For LED board replacement reference 689-0853 Instruction Sheet.

3.) Driver maintenance:

Drivers are located in fixture beneath direct reflectors. See below lens, reflector & driver removal.

For **programmable** driver replacement please specify: **Manufacturer, Model No.** and **Current Setting** (____ mA).

See Wiring Schematic 710-0183 for Direct
710-0184 for Direct/Indirect

Lens Removal/Installation (Tool Required - Putty Knife or similar)

To Remove: Insert putty knife under lens and pry lens to one side. Continue until one side of lens comes out.

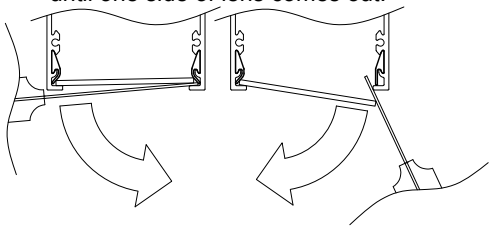

To Install: Insert Lens into one side at an angle and push into flexible lens clip. Tilt lens up past bottom flange and into fixture.

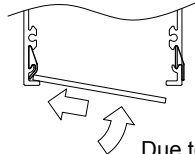

If lens shows a gap on one side squeeze fixture to center lens between lens clips.

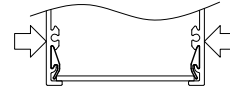

Due to the thin nature of the lens, longer lengths may require (2) people for installation.

LED/Driver Replacement

Remove LED Tray:

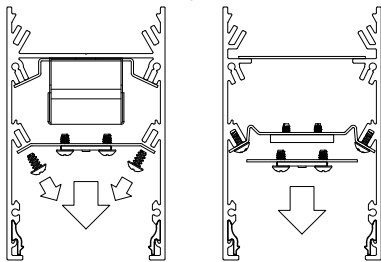

Straight sections removed via mounting screws. Curved sections removed by pulling tray away from magnet.

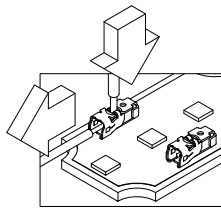

Remove wires by inserting small pin (pushpin, solid wire, etc.) in top of connector to release wire.

See 689-0853 for board replacement details.

Remove LED Driver (Straight Sections):

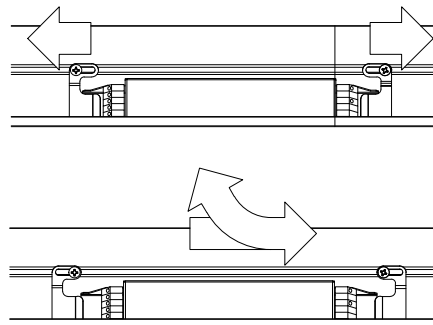

Loosen screws in driver brackets (Do not remove) and slide away from driver.

Shift driver to one side and tilt out of fixture.

To install new driver, install under mounting brackets, slide brackets over driver and tighten screws

Remove LED Driver (Curved Corner): D72 & D100 Only

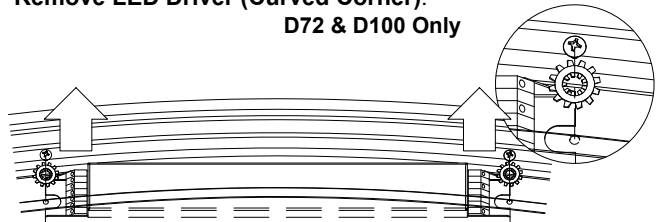

Remove screws holding driver to housing to remove driver.