

HORNET® HP DOWNLIGHT

3.5" ROUND LENSED DOWNLIGHT TRIMLESS LED INTERNATIONAL

I-HDL-HP-RLD-A14-TL
LED



APPLICATIONS:

Retail and commercial ambient lighting

CONSTRUCTION:

Die-cast aluminum trim ring
Cast aluminum plaster frame with perforated face
Die-cast optical housing and trim
Extruded aluminum heat sink

ELECTRICAL:

Electronic constant current LED driver, 240v input
ELV and Triac dimming standard
Dimming options available for ELV, and DALI systems.
This product complies with IEEE C62.41 for surge endurance up to 2.5KV. Amerlux® recommends using additional surge protection with this unit (supplied by others), surge damage is not covered by warranty.

OPTICS:

High reflectance, highly diffuse mixing chamber
Engineered nano technology lens provides transmission while concealing LED image
LED:
Color Temp Options: 2200K, 2700K, 3000K, 3500K, 4000K
CRI: 83 typ. (2700K, 3000K, 3500K, 4000K)
90+ typ. (2200K, 2700K, 3000K)
Optional Amerlux CrispWhite technology
R9 Value: 11 (83CRI), 55 (90+CRI)
Binning: 3 MacAdam (SDMC)
Lumen Maintenance: >70% of initial lumens @ 50,000 hrs
Lumen Output (at 3000K):
Very Wide Flood (75°): 14W - 911 lm, 21W - 1310 lm

LABELING:

CE
For indoor use only
Damp location

PROJECT:

TYPE:

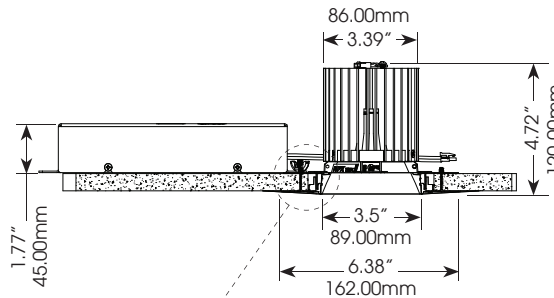
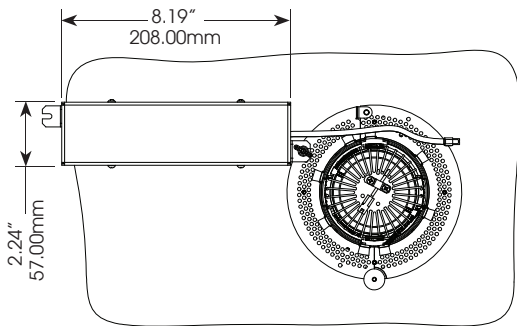

Ceiling Cut Out Dimension: 4.5" (114.50 mm)

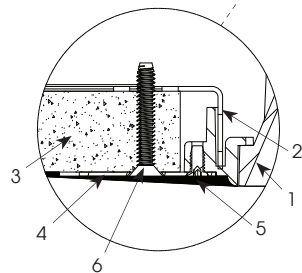

1. Reflector Trim
2. Die-cast trim ring
3. Ceiling 1/2" (1" Max.)
4. Cast Aluminum Plaster Frame
5. Plaster Skim Coat (By Others)
6. #6 Screw (by others)

ELECTRICAL

Electronic driver		14W		21W	
System	Watts	Amps	System	Watts	Amps
240V	14	0.06	21	0.09	



114.5 mm

3 year limited warranty
AMERLUX INTERNATIONAL
(see website for details)

ORDERING INFORMATION:

Model	Wattage	Lamp Type	Voltage	Aperture Finish	Color Temp (CCT-CRI)	Listing Code	Options
I-HDL-HP-RLD-A14-TL	14 21	LED	240	MB - matte black MW - matte white SLV - matte silver	27 - 2700K-83 30 - 3000K-83 35 - 3500K-83 40 - 4000K-83 229 - 2200K-90+ 279 - 2700K-90+ 309 - 3000K-90+ CRISP - CrispWhite 3CLA - 3K Class A	CE	DALI - DALI driver

Example: I-HDL-HP-RLD-A14-TL-21-LED-240-MW-30-CE

Cat #:

Amerlux reserves the right to change details that do not affect overall function and performance.



HORNET® HP DOWNLIGHT

3.5" ROUND LENSED DOWNLIGHT TRIMLESS LED INTERNATIONAL

I-HDL-HP-RLD-
A14-TL
LED



TYPE:



FIXTURE DATA: For 14W data, multiply by 0.67

Complete photometric data (ies format) available upon request.

CCT Conversion Factor: 2700K-83 = 0.96; 3500K-83 = 1.02; 4000K-83 = 1.04; 2200K-90+ = 0.71; 2700K-90+ = 0.80; 3000K-90+ = 0.83; CRISP = 0.65; 3CLA = 0.75

21W LED 3000K-83

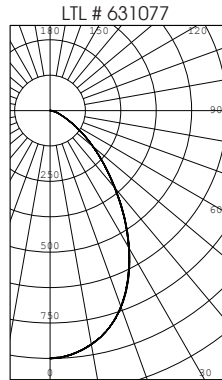

Candelas at Nadir	
Deg	Candela
0	875
5	866
15	797
25	653
35	455
45	271

APPLICATION DATA:

Notes and Definitions:

Beam spread is to 50% center beam candlepower (CBCP).
 D=Distance to floor or wall.
 FC=Footcandles on floor or wall at center beam aiming location.
 L=Effective Visual Beam length in feet (50% of maximum footcandle level).
 W=Effective Visual Beam width in feet (50% of maximum footcandle level).
 CB=Distance across or down to center beam location.

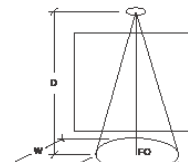

0° Aiming Angle
Horizontal
Footcandles

D	FC	L	W
5.0'	36	5.1	5.1
7.5'	16	7.7	7.7
10.0'	9	10.3	10.3
12.5'	6	13.5	13.5