

BR08D

Crossarm

PROJECT:

TYPE:

Description

The BR08D Series crossarms feature a strong yet lightweight aluminum design for ease of installation. The series can accommodate a wide variety of fixtures. It is designed to be used on a pole with a min. 4" OD shaft.

Construction

Crossarms are shipped as a one piece unit as shown. Crossarms are constructed from ASTM 319 aluminum. Exterior hardware is stainless steel and tamper resistant

Installation

Crossarms will slip fit a 3" OD post top tenon and attach with two rows of 5/16" dia. stainless steel set screws. Crossarms and wall brackets are equipped with 3" O.D. tenons for luminaire mounting.

The wall bracket is constructed of corrosion resistant cast aluminum (A319 Alloy). It has a nominal 3" OD tenon for luminaire mounting, and four holes in the back plate for mounting to the wall. (Wall mounting hardware is not included, due to the wide variety of backing materials. Customer should determine the appropriate anchoring hardware based on the wall material.)

Finish

The bracket will be finished with a premium quality thermoset polyester powdercoat for a durable finish.

BLK - Satin Black

CLB - Classic Bronze

GBZ - Gloss Textured Bronze

GRN - Green

GTB - Gloss Textured Black

TBK - Textured Black

TGR - Gloss Textured Green

CSTM - Custom

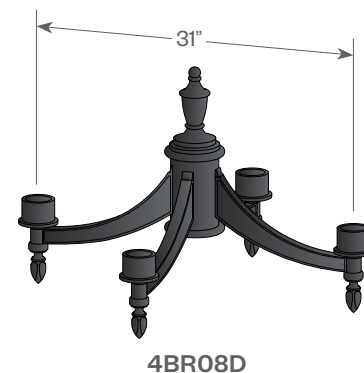
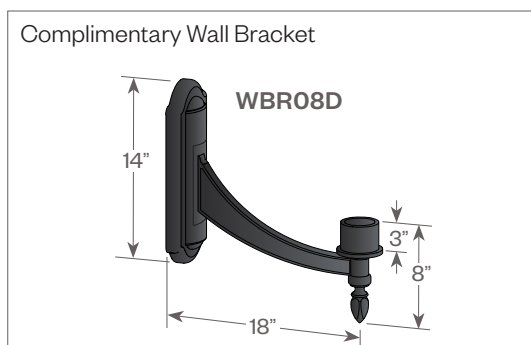
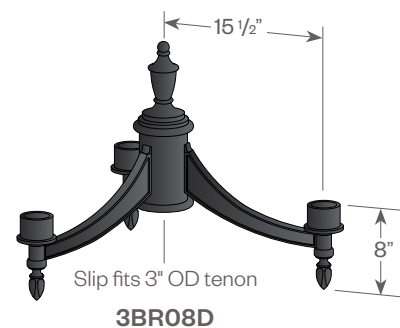
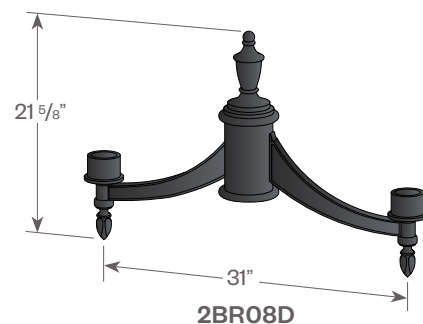

BR08D

Crossarm



PROJECT:

TYPE:

Ordering Information

1

2

1

Model

2BR08D

3BR08D

4BR08D

WBR08D (wall bracket)

2

Finish

BLK - Satin Black

CLB - Classic Bronze

GBZ - Gloss Textured Bronze

GRN - Green

TGR - Gloss Textured Green

TBK - Textured Black

GTB - Gloss Textured Black

CSTM - Custom